

English version

**Alarm systems -
Intrusion and hold-up systems -
Part 6: Power supplies**

Systemes d'alarme -
Systemes d'alarme contre l'intrusion
et les hold-up -
Partie 6: Alimentation

Alarmanlagen -
Einbruch- und Überfallmeldeanlagen -
Teil 6: Energieversorgungen

This draft European Standard is submitted to CENELEC members for Unique Acceptance Procedure.
Deadline for CENELEC: 2007-09-07.

It has been drawn up by CLC/TC 79.

If this draft becomes a European Standard, CENELEC members are bound to comply with the CEN/CENELEC Internal Regulations which stipulate the conditions for giving this European Standard the status of a national standard without any alteration.

This draft European Standard was established by CENELEC in three official versions (English, French, German). A version in any other language made by translation under the responsibility of a CENELEC member into its own language and notified to the Central Secretariat has the same status as the official versions.

CENELEC members are the national electrotechnical committees of Austria, Belgium, Bulgaria, Cyprus, the Czech Republic, Denmark, Estonia, Finland, France, Germany, Greece, Hungary, Iceland, Ireland, Italy, Latvia, Lithuania, Luxembourg, Malta, the Netherlands, Norway, Poland, Portugal, Romania, Slovakia, Slovenia, Spain, Sweden, Switzerland and the United Kingdom.

Warning : This document is not a European Standard. It is distributed for review and comments. It is subject to change without notice and shall not be referred to as a European Standard.

CENELEC

European Committee for Electrotechnical Standardization
Comité Européen de Normalisation Electrotechnique
Europäisches Komitee für Elektrotechnische Normung

Central Secretariat: rue de Stassart 35, B - 1050 Brussels

Foreword

This draft European Standard was prepared by the Technical Committee CENELEC TC 79, Alarm systems. It is submitted to the Unique Acceptance Procedure.

This draft European Standard will supersede EN 50131-6:1997.

The following dates are proposed:

- latest date by which the existence of the EN has to be announced at national level (doa) dor + 6 months
- latest date by which the EN has to be implemented at national level by publication of an identical national standard or by endorsement (dop) dor + 12 months
- latest date by which the national standards conflicting with the EN have to be withdrawn (dow) dor + 36 months (to be confirmed or modified when voting)

EN 50131 will consist of the following parts, under the general title *Alarm systems - Intrusion and hold-up systems*:

- Part 1 System requirements
- Part 2-2 Intrusion detectors - Passive Infrared detectors
- Part 2-3 Intrusion detectors - Microwave detectors
- Part 2-4 Intrusion detectors - Combined passive infrared /Microwave detectors
- Part 2-5 Intrusion detectors – Combined passive infrared /Ultrasonic detectors
- Part 2-6 Intrusion detectors - Opening contacts
- Part 2-7 Intrusion detectors - Glass break detectors, acoustic or seismic
- Part 2-8 Intrusion detectors - Vibration detectors
- Part 2-9 Intrusion detectors - Active infrared detectors
- Part 2-10 Intrusion detectors - Proximity detectors
- Part 3 Control and indicating equipment
- Part 4 Warning devices
- Part 5-1 Requirements for interconnections equipment using dedicated wired links
- Part 5-2 Requirements for interconnections equipment using non-dedicated wired links
- Part 5-3 Requirements for interconnections equipment using radio frequency techniques
- Part 6 Power supplies
- Part 7 Application guidelines
- Part 8 Security fog devices

Contents

Introduction	5
1 Scope	6
2 Normative references	6
3 Definitions and abbreviations	7
3.1 Definitions	7
3.2 Abbreviations	9
4 Functional Requirements	9
4.1 General	9
4.2 Monitoring of PS	11
4.3 APS Capability	14
4.4 Recharging for PS Type A	14
4.5 Over-voltage Protection	15
4.6 Short Circuit Protection	15
4.7 Overload Protection	15
4.8 Deep Discharge Protection	15
4.9 Automatic changeover to APS	15
4.10 Ripple	15
4.11 Tamper Security.....	16
4.12 Environmental	17
4.13 Safety	18
4.14 EMC	19
4.15 Electrical	19
5 Marking	20
6 Documentation	20
7 Tests	21
7.1 General test conditions	22
7.2 Reduced Functional Test	22
7.3 PS Rating	23
7.4 Output Voltage Stability - Gradual Load Variation	24
7.5 Output Voltage Stability – Switched Load Variation	25
7.6 Signalling: Loss of EPS.....	26
7.7 Signalling: Storage Device – Low Voltage.....	27
7.8 Signalling: Storage Device – Failure.....	28
7.9 Signalling: Low Output Voltage.....	29
7.10 Signalling: Power Unit Failure.....	30
7.11 Signalling: Power Unit Failure – SD Charging	30
7.12 Remote Test Request	31
7.13 SD Recharging.....	32
7.14 Over Voltage Protection.....	33
7.15 Short Circuit protection	34
7.16 Overload Protection	35
7.17 Deep Discharge Protection.....	36
7.18 Automatic Changeover to APS	37

7.19	Tamper Protection	37
7.20	Resistance to and detection of unauthorised access to components and means of adjustment	38
7.21	Tamper Detection – Removal from Mounting.....	39
7.22	Tamper Detection – Penetration of the housing	40
7.23	Environmental and EMC	40
7.24	Marking and Documentation.....	41
Annex A (informative) Determination of Storage device failure.....		42
Figure 1 — Power Supply Types.....		10
Table 1 — Power Supply Functions		11
Table 2 — Power Supply Signalling		12
Table 3 — Maximum Time to Detect and Signal Storage Device – Low Voltage		13
Table 4 — Tamper Detection		16
Table 5 — Removal from Mounting.....		17
Table 6 — Environmental and EMC Tests and Severity.....		18
Table 7 — Tests for PS according to Type		21
Table A.1 — Minimum Load times for Common Storage Devices in Use in I&HAS.....		42

Introduction

This European Standard deals with power supplies (PS) of intrusion and hold-up alarm systems (I&HAS) installed in buildings. It includes devices that are installed inside or outside of the supervised premises and mounted in indoor or outdoor environments.

Draft for Vote

1 Scope

This European Standard specifies the requirements, performance criteria and testing procedures for PS to be used as part of Intrusion and Hold up Alarm Systems. The PS shall either be an integral part of an I&HAS component or stand-alone. The control functions of the PS may be incorporated as part of the PS device, or may be provided by another I&HAS component e.g. a CIE.

This European Standard is not applicable when the PS requirements for I&HAS components are included within the relevant product standard.

The requirements correspond to each of the four security grades given in the European Standard EN 50131-1, Alarm Systems – Intrusion and Hold-Up Systems - system requirements. Requirements are also given for four environmental classes covering applications in internal and outdoor locations.

This standard covers mandatory functions which shall be provided on all PS and optional functions which may be provided.

Other functions associated with I&HAS not specified in this standard may be provided. Such functions shall not affect the requirements of any mandatory or optional functions.

2 Normative references

The following referenced documents are indispensable for the application of this document. For dated references, only the edition cited applies. For undated references, the latest edition of the referenced document (including any amendments) applies.

<u>Publication</u>	<u>Year</u>	<u>Title</u>
EN 50130-4	1995	Alarm systems - Part 4 : Electromagnetic compatibility - Product family standard : immunity requirements for components of fire, intruder and social alarm systems
EN 50130-5	1998	Alarm systems - Part 5 : Environmental test methods
EN 50131-1	2006	Alarm systems - Intrusion and hold-up systems - Part 1: System requirements
EN 60065 ¹⁾	1998	Audio, video and similar electronic apparatus - Safety requirements (IEC 60065:1998, mod)
EN 60068-1	1994	Environmental testing - Part 1: General and guidance (IEC 60068-1:1988 + corrigendum October 1988 + A1:1992)
EN 60529	1991	Degrees of protection provided by enclosures (IP code) (IEC 60529:1989)
EN 60950	Series	Information technology equipment - Safety (IEC 60950 series, partly modified)
EN 61000-6-3 ²⁾	2001	Electromagnetic compatibility (EMC) - Part 6-3: Generic standards – Emission standard for residential, commercial and light industrial environments (IEC 61000-6-3:1996, mod.)
EN 62262	2002	Degrees of protection provided by enclosure for electrical equipment against external mechanical impacts (IK code) (IEC 62262:2002)

¹⁾ EN 60065:1998 is superseded by EN 60065:2002, which is based on IEC 60065:2001 (dow = 2007-03-01).

²⁾ EN 61000-6-3:2001 is superseded by EN 61000-6-3:2007, which is based on IEC 61000-6-3:2006 (dow = 2009-12-01).

3 Definitions and abbreviations

3.1 Definitions

For the purposes of this European Standard, the following definitions apply:

3.1.1

alternative power source (APS)

power source capable of powering the I&HAS for a predetermined time when the EPS is unavailable

3.1.2

deep discharge protection

protection which avoids damage to the storage device when the level of discharge is beyond the level specified by the storage device manufacturer

3.1.3

external power source (EPS)

energy supply external to the I&HAS which may be non-continuous. For Type A and Type B PS only. The EPS is provided by the PPS or the SPPS

3.1.4

independent power outputs

individual power output to the I&HAS having its own protection against short circuit and overload. Each output may have provision for more than one connection

3.1.5

low output voltage

voltage below the minimum power output voltage

3.1.6

maximum power output voltage

maximum rated voltage of the PS at each independent power output as specified by the PS manufacturer under normal operating conditions

3.1.7

minimum power output voltage

minimum rated voltage of the PS at each independent power output as specified by the PS manufacturer under normal operating conditions

3.1.8

normal operating condition

conditions applying when the PS is mounted according to the PS manufacturer's instructions, within the range of the designated environmental class, the applied load is within the rated output, the SD has sufficient charge to maintain the minimum power output voltage and for Type A and Type B, any applied and available EPS is within specified range

NOTE Normal operating condition of a PS includes APS operation.

3.1.9

open by normal means

opening of the equipment housing by the procedure defined by the manufacturer.

3.1.10

over-voltage protection

protection of the PS output against excessive high output voltage due to failure of one or more PS components under normal operating conditions

3.1.11**power output**

output of the PS that supplies energy to the I&HAS

3.1.12**power unit (PU)**

device that provides and also modifies or isolates (electrical) power for an I&HAS or part thereof and for the SD if required

3.1.13**power supply (PS)**

device that stores, provides and also modifies or isolates (electrical) power for an I&HAS or part thereof, comprising of a PU and SD as a minimum

3.1.14**prime power source (PPS)**

energy source capable of supporting the I&HAS for extended periods e.g. mains supply

3.1.15**rated output**

the total continuous output current that can be supplied by the PS to the I&HAS through its independent power outputs under normal operating conditions

3.1.16**ripple**

oscillating voltage superimposed onto the dc voltage at an independent output

3.1.17**supplementary prime power source (SPPS)**

energy source independent of the PPS capable of supporting the I&HAS for extended periods e.g. standby generator

3.1.18**standby period**

time period during which the APS is capable of supporting an I&HAS in the event of failure of the EPS

3.1.19**APS operating period**

period during which the APS is supporting an I&HAS when the EPS has been lost

3.1.20**storage device (SD)**

device which stores energy e.g. a battery

3.1.21**storage device - low voltage**

voltage specified by the PS manufacturer which indicates that the storage device is nearly discharged

3.1.22**storage device – failure**

a condition of the SD where it cannot supply the rated power output of the PS at the minimum power output voltage

3.1.23**trickle charging**

a condition of the SD where a charging voltage is applied to hold the SD at nominally 100 % charge

3.1.24

power unit failure

a condition of the PU where it cannot supply the rated power output and/or for a PS Type A cannot recharge the SD

3.1.25

power supply failure

a condition in which a SD failure or a PU failure is present

3.2 Abbreviations

For the purposes of this European Standard the following abbreviations are used:

APS	Alternative Power Source
CIE	Control and Indicating Equipment
EPS	External Power Source
I&HAS	Intruder and Hold-up Alarm System
PPS	Prime Power Source
PS	Power Supply
PU	Power Unit
SD	Storage Device
SPPS	Supplementary Prime Power Source
ac	alternating current
dc	direct current

4 Functional Requirements

4.1 General

The PS shall supply power to the components of the I&HAS continuously.

There are three Types of PS which are independent of security grade. These Types are illustrated in Figure 1.

The PS Types are defined in EN 50131-1.

One or more PS may be used to meet the I&HAS standby requirements as specified in EN 50131-1.

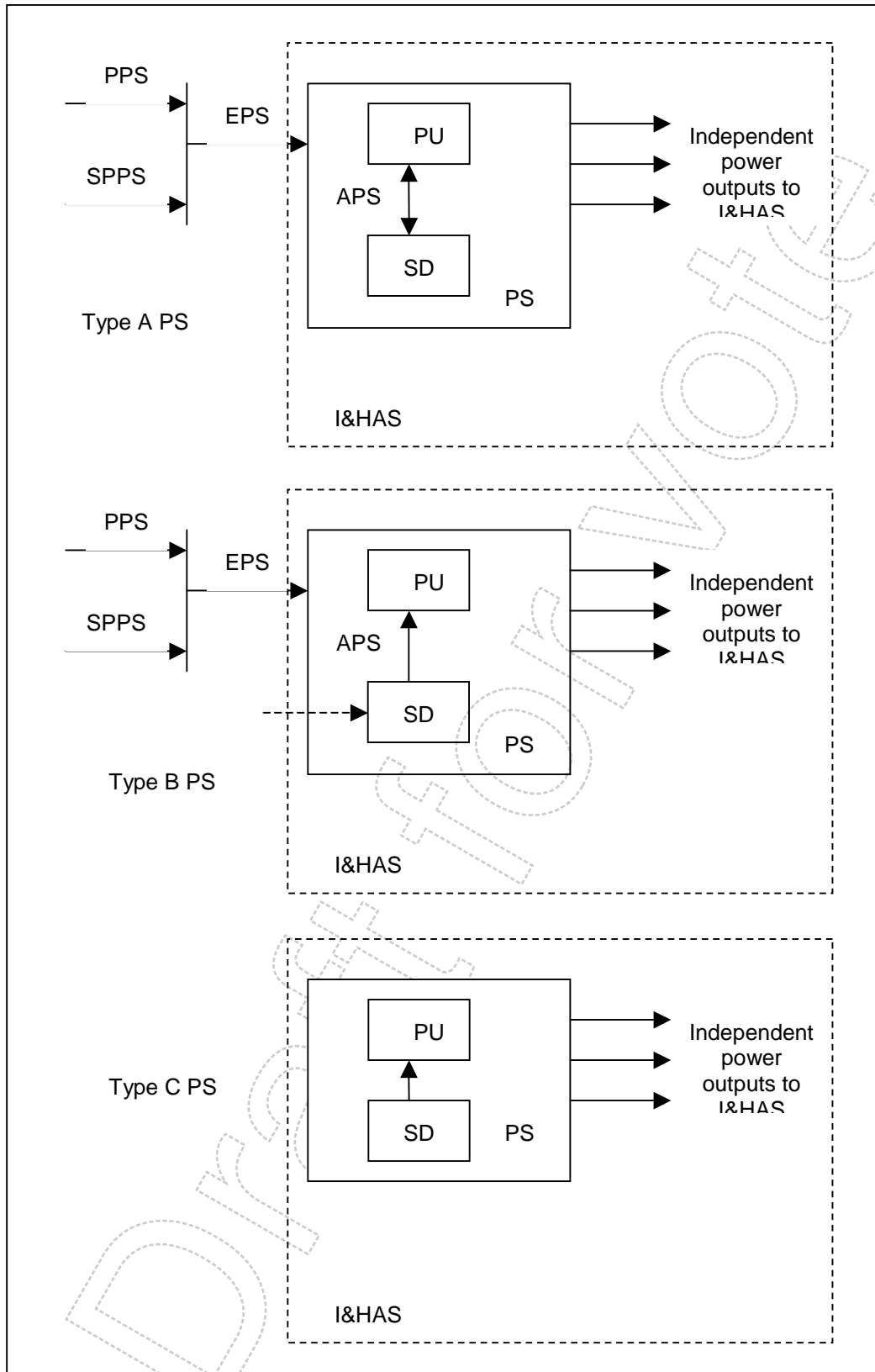

NOTE For PS Type A and B, where there is no SPPS, the PPS and EPS are identical.

Figure 1 — Power Supply Types

Depending upon the security grade and PS Type, the PS shall have the functionality as defined in Table 1. A function designated in this standard as optional for a particular grade may be provided by the manufacturer. If provided, it will be tested in accordance with Clause 7 and shall meet all the declared grade requirements according to this standard. If the test result is a pass, the manufacturer may claim the extra function. This does not alter the overall grading of the PS.

Table 1 — Power Supply Functions

Function	Grade	PS Type		
		A	B	C
Detection of Loss of EPS	1 – 4	M	M	n/a
Detection of Storage Device – Low Voltage	1 – 4	M	M	M
Detection of Storage Device – Failure	1 – 2	Op	Op	n/a
	3 – 4	M	Op	n/a
Detection of Low Output Voltage	1 – 2	Op	Op	n/a
	3 – 4	M	M	n/a
Detection of Power Unit failure	1 – 2	Op	Op	n/a
	3 – 4	M	M	n/a
Over-voltage Protection	1 – 2	Op	Op	Op
	3 – 4	M	M	Op
Short circuit protection	1 – 4	M	M	M
Overload protection	1 – 4	M	M	M
SD Deep Discharge protection ^a	1 – 2	Op	Op	n/a
	3 – 4	M	M	n/a
Remote Test Request	1 – 3	Op	Op	n/a
	4	M	Op	n/a
Tamper Security	1 – 4	M	M	M
^a Where Deep Discharge will damage the SD M = Mandatory Op = Optional n/a = Not Applicable				

4.2 Monitoring of PS

The PS shall generate fault signals or messages according to Table 2 that can give an indication at the CIE.

Monitoring signals or messages shall be fail safe such that total loss of function of the PS will be recognised as a fault condition by the I&HAS.

Table 2 — Power Supply Signalling

Condition	EPS Fault signal or message	APS Fault signal or message	Storage Device Low Voltage signal or message	Power Output Fault signal or message	Tamper signal or message
Loss of EPS	M	NP	n/a	NP	NP
Storage Device – Low Voltage: PS Type A, B	NP	M	n/a	NP	NP
Storage Device – Low voltage: PS Type C	n/a	NP	M	NP	NP
Storage Device – Failure ^a	NP	M	n/a	NP	NP
Power Unit – Failure ^a	NP	NP	NP	M	NP
Low Output Voltage ^a	Op	Op	Op	M	NP
Tamper Detection	NP	NP	NP	NP	M
Remote Self Test	NP	Op	NP	NP	NP
^a Dependent upon security grade M = Mandatory NP = Not permitted n/a = Not Applicable Op = Optional					

4.2.1 Loss of EPS

A loss of EPS condition shall be detected within 1 s.

When the EPS has been continuously disconnected for a minimum of 1 s and a maximum of 60 s, an EPS fault signal shall be generated.

After a loss of EPS, when the EPS is restored the re-connection condition shall be detected within 1 s.

When the EPS has been continuously re-connected for a minimum of 1 s and a maximum of 60 s an EPS fault signal shall be removed

4.2.2 Storage Device – Low Voltage

The voltage of the storage device shall be monitored to give an indication that the SD voltage is low.

For PS Type A and B:

An APS Fault signal or message shall be generated according to Table 2 and within the maximum time periods defined in Table 3, when the voltage of the SD falls below a low value as specified by the PS manufacturer.

An APS Fault signal or message shall be removed according to Table 2 and within the maximum time periods defined in Table 3, when the voltage of the SD rises above the low value specified by the PS manufacturer.

NOTE 1 A disconnected SD is considered a special case of low voltage.

NOTE 2 For PS Type A it is not necessary to monitor for storage device low voltage when the storage device is undergoing normal charging.

For PS Type C:

A storage device low voltage fault signal or message shall be generated within the maximum time periods defined in Table 3, before the SD reaches a condition such that it is unable to provide its rated output for longer than a minimum of 30 days.

A storage device low voltage fault signal or message shall be removed within 10 s according to Table 2, when the voltage of the SD rises above the low value specified by the PS manufacturer e.g. following replacement of the battery.

For all PS Types, the PS manufacturer shall declare in his documentation the voltage of the SD that will generate this fault signal or message.

Table 3 — Maximum Time to Detect and Signal Storage Device – Low Voltage

Maximum Time to Detect and Signal Storage Device – Low Voltage	Grade 1	Grade 2	Grade 3	Grade 4
Type A and B PS	5 min	5 min	5 min	5 min
Type C PS ^a	240 min	120 min	120 min	120 min

^a For wirefree devices with intermittent operation e.g. portable ACE, it is permissible for communication of the low voltage fault signal or message to be delayed until the first available transmission.

4.2.3 Storage Device – Failure

For PS Type A, a SD failure condition shall be detected within 24 h of failure of the SD.

An APS Fault signal or message shall be generated within 10 s of detection of SD failure.

Examples of methods deemed suitable to determine a storage device failure condition are given in Annex A.

The APS Fault signal or message shall be removed within 10 s of detection of a normal storage device condition

If the PS is designed to be connected to two or more storage devices in a parallel configuration in accordance with the guidance of the SD manufacturer, they shall be monitored as separate storage devices. An APS Fault signal or message shall be generated upon detection of failure for any one device. The APS fault signal or message shall be removed only when all devices no longer show a failure condition.

These tests must only be applied when the EPS is available.

Following disconnection and reconnection of the EPS, this test may be delayed for up to 24 h to enable recharge of the SD.

4.2.4 Low Output Voltage

For PS Type A and B Grades 3 and 4, a Power Output Fault signal or message shall be generated within 10 s of the voltage on one or more independent power output falling below the minimum power output voltage e.g. due to failure in the power supply or intervention of an output protection device.

The Power Output Fault signal or message shall be removed within 10 s of the voltage on all independent power outputs rising above the minimum power output voltage.

4.2.5 Power Unit failure

When the EPS is present, for PS Type A and B Grades 3 and 4, the PU shall be monitored to detect if it can no longer supply the rated power output voltage from the EPS.

NOTE this includes a failure of the PU which would not normally result in a low power output voltage due to the SD operating as the APS

When the EPS is present, for PS Type A Grades 3 and 4, the PU shall be monitored to detect if it can no longer recharge the SD.

A Power Output Fault signal or message shall be generated within 10 s of detection of either of these conditions.

The Power Output Fault signal or message shall be removed within 10 s of the restoration of the normal operation of the PU.

4.2.6 Remote Test Request

PS Type A at Grade 4 shall have means to receive a signal or message to trigger the PS internal tests of Storage Device Failure.

The resulting test sequence shall not prevent the PS from operating in accordance with Tables 1 and 2.

The PS shall acknowledge receipt of the remote test request within 10 s of receipt of the remote test request.

When the test is initiated, the PS shall not remain in test mode for a period in excess of 60 s. If no dedicated acknowledge facility is available, the APS Fault signal or message shall be used to communicate the remote test request acknowledgement and the pass or fail result

4.3 APS Capability

A PS Type A and B shall be capable of continuously supplying its rated output to the I&HAS in the event of interruption of the EPS.

The PS manufacturer shall specify the minimum and maximum storage device capacity that can be used with the PS

The PS manufacturer shall provide sufficient information to enable calculation of the minimum time period that the PS can continuously supply its rated output when fitted with a range of storage devices.

NOTE Where the SD is a battery, it is not necessary to take into account the differences in available capacity at differing levels of discharge rate and a simple relationship between battery capacity (Ah), time (h) and current available (A) is acceptable.

4.4 Recharging for PS Type A

When fitted with a storage device of capacity as defined by the PS manufacturer, the power supply shall be capable of recharging the storage device to 80 % of this storage device capacity following discharge to the minimum level recommended by the storage device manufacturer or the level at which deep discharge protection has been activated.

The storage device shall be automatically recharged from the EPS within the maximum recharge periods as specified in EN 50131-1.

NOTE If the SD is faulty and its terminal voltage is too low for safe recharging, then it is permissible for the PS not to automatically recharge the SD when the EPS is reconnected providing the APS fault signal or message is still active.

The PS must be capable of supplying its rated output continuously during recharge of the storage device.

The charging characteristics used by the PS to recharge the SD shall remain within the limits recommended by the SD manufacturer.

A Grade 4 PS shall ensure that during trickle charging, the charging characteristics are within the SD manufacturer's specifications for the range of SD temperatures reached for the environmental class.

4.5 Over-voltage Protection

To prevent damage being caused to other I&HAS components due to failure of any single PS component, PS grades 3 and 4 shall include protection to ensure that the voltage at any independent power output does not exceed 125 % of the maximum power output voltage.

4.6 Short Circuit Protection

Each independent power output shall be protected against short circuit in the connected load.

Following removal of the short circuit and reset of any protection device, all independent power outputs shall continue to operate normally.

A short circuit in the load connected to any independent power output shall not reduce the functionality of any other independent output.

Any transients that are generated during operation of the protection shall meet the requirements of 4.15.7.

4.7 Overload Protection

Each independent power output shall be protected against overload condition in the connected load.

Following removal of the overload and reset of any protection device, all independent power outputs shall continue to operate normally.

An overload condition on any independent power output shall not reduce the functionality of any other independent output.

Any transients that are generated during operation of the protection shall meet the requirements of 4.15.7.

4.8 Deep Discharge Protection

When deep discharge of a storage device may cause damage to the storage device, protection shall be provided in PS for Grades 3 and 4. The PS manufacturer shall declare the voltage of the SD below which this protection shall operate and this shall be less than the minimum power output voltage.

4.9 Automatic changeover to APS

Any transients that are generated during the changeover period between EPS and APS operation shall meet the requirements of 4.15.7.

4.10 Ripple

For PS with dc outputs, the peak to peak ripple content of the voltage at any independent power output shall be as specified by the PS manufacturer and shall not exceed 5 % of the maximum power output voltage.

4.11 Tamper Security

Where the PS is housed with one or more components of an I&HAS, the tamper security requirement of the PS shall be that of those components.

Where the PS is housed in a separate enclosure, the enclosure shall meet the tamper security requirements of this section.

4.11.1 Tamper Protection

The construction of the power supply enclosure shall meet the tamper protection requirements of EN 50131-1.

Provision shall be made to allow adequate fixing of the enclosure to the mounting surface.

NOTE Impact resistance requirements are covered by the environmental requirements of Clause 7.

4.11.2 Tamper Detection

A tamper signal or message shall be generated according to the requirements as specified in Table 4 and before access can be gained to override the detection.

Table 4 — Tamper Detection

Event	Grade 1	Grade 2	Grade 3	Grade 4
Detection of access to the inside of the PS	M	M	M	M
Removal from mounting	Op	Op	M	M
Penetration of housing	Op	Op	Op	M
M = Mandatory Op = Optional				

4.11.2.1 Resistance to and detection of unauthorised access to components and means of adjustment

All components, means of adjustment and access to mounting screws, which, when interfered with, could adversely affect the operation of the PS, shall be located within the PS housing. Such access shall require the use of an appropriate tool and depending on the grade as specified in Table 4 shall generate a tamper signal or message before access can be gained.

It shall not be possible to gain such access without generating a tamper signal or message or causing visible damage.

4.11.2.2 Removal from mounting

Attempts to remove the power supply from its mounting surface for a distance defined in Table 5 shall generate a tamper signal or message according to Table 4.

It should not be possible to defeat the removal from mounting detection by sliding a 1 mm thick blade between the mounting surface and the power supply.

Table 5 – Removal from Mounting

	Grade 1	Grade 2	Grade 3	Grade 4
Maximum distance before tamper detection	10 mm	10 mm	5 mm	5 mm

4.11.2.3 Penetration of the housing

When mounted according to the PS manufacturer's instructions, it shall not be possible to penetrate the housing of the PS through any of its accessible faces with a tool creating a hole of 4 mm or greater without generating a tamper signal or message according to Table 4.

NOTE The aim is to detect a reduction of the original integrity of the housing. The definition of the hole diameter is to set an objective threshold for both product design and performance verification.

4.12 Environmental

The environmental classification is described in EN 50131-1. All the relevant environmental tests shall be carried out in accordance with EN 50130-5.

Where the PS is housed with one or more components of an I&HAS, the environmental requirement of the PS shall be that of those components. In addition, for Type C PS, the environmental test shall be made with the SD inside the component with the exception of the endurance test and this SD shall be fully charged

For operational tests, the power supply shall not generate tamper, fault or other signals or messages, when subjected to the specified range of environmental conditions and shall continue to supply its continuous rated output.

For endurance tests, the power supply shall continue to meet the requirements of this standard after being subjected to the specified range of environmental conditions.

See Table 6 for the relevant tests for each environmental class. These tests apply to all security grades.

Four representative samples, each able to be subjected to the reduced functional test, shall be provided to the Test House for the environmental testing.

Table 6 — Environmental and EMC Tests and Severity

	Reduced functional test:	Test	Type	Class I	Class II	Class III	Class IV
1	B, D, A	Dry heat	Operational	M	M	M	M
2	B, A	Dry heat	Endurance				M
3	B, D, A	Cold	Operational	M	M	M	M
4	B, D, A	Damp heat, steady state	Operational	M			
5	B, A	Damp heat, steady state	Endurance	M	M	M	M
6	B, D, A	Temperature change	Operational	M ^a	M ^a	M ^a	M ^a
7	B, D, A	Damp heat, cyclic	Operational		M	M	M
8	B, A	Damp heat, cyclic	Endurance			M	M
9	B, D, A	Water ingress	Operational	M ^a	M ^a	M	M
10	B, A	Sulphur Dioxide (SO ₂)	Endurance			M ^b	M ^b
11	B, A	Salt mist, cyclic	Endurance				M
12	B, C, A	Impact	Operational	M	M	M	M
13	B, C, A	Shock	Operational	M	M	M	M
14	B, A	Vibration, sinusoidal	Operational	M	M	M	M
15	B, D, A	EMC (Susceptibility)	Operational	M	M	M	M
16	B, E	EMC (Emissions)	Operational	M	M	M	M
<p>B Before conditioning. D During conditioning, as specified in EN 50131-1 (Clause 12), EN 50130-5 and EN 50130-4. A After conditioning and recovery period. C Monitor during conditioning. E During conditioning, as specified in EN 50131-1, EN 50131-3 and EN 50131-6 tests have to be performed as specified in EN 61000-6-3. M Mandatory.</p>							
<p>^a Portable equipment only ^b Only for equipment having a tamper detection device</p>							

4.13 Safety

The power supply shall provide protection against electrical shock and consequential hazards in accordance with the requirements of EN 60950 or EN 60065.

4.14 EMC

For all grades, the power supply shall not generate, or be affected by, the EMC conditions and severity levels defined in EN 50130-4 and EN 61000-6-3.

4.15 Electrical

4.15.1 Connections

The means of electrical connection shall be appropriate for the physical size and current carrying capacity of the required conductors. The method of termination shall not damage the conductors.

Terminal blocks and other components utilised for connections shall be identifiable with numbers or other marks specified in the documentation

4.15.2 Rated Output

Under normal operating conditions and when fitted with a SD of maximum capacity as defined by the PS manufacturer, the power supply shall deliver its rated output voltage / current continuously. limited during APS operation to the time periods specified in EN 50131-1, via its independent power outputs into any load except as may be otherwise specified by the PS manufacturer.

The power requirement of any integrated component e.g. CIE, or PS control components shall be declared in the PS manufacturer's documentation.

NOTE there should be sufficient information contained in the PS documentation to enable the PS user to correctly determine the power that is available to any other connected I&HAS components.

4.15.3 Output Voltage Range

Under normal operating conditions, the voltage at the independent power outputs shall lie between the minimum power output voltage and the maximum power output voltage with a load connected and drawing no greater than the rated output of the power supply.

4.15.4 Input Voltage Range

For power supplies Type A and B, the requirements of 4.15.3 shall be met when any applied and available EPS lies within the range of 230 V AC +10 %, - 15 % at a frequency as specified by the PS manufacturer.

4.15.5 Output Voltage Stability – Gradual Load Variation

A gradual and continuous load variation on anyone independent power output shall not reduce the functionality of this or any other independent power output.

4.15.6 Output Voltage Stability – Switched Load Variation

A switched load variation on any independent power output shall not reduce the functionality of any independent power output.

Any transients that are generated during the load variation shall meet the requirements of 4.15.7.

4.15.7 Transients on the power outputs

Transients on any independent Power Output during operation of the PS shall be limited to:

- a) no more than 125 % of the maximum power output voltage and no less than 95 % of the minimum power output voltage for a period not exceeding 200 ms, and
- b) no more than 140 % of the maximum power output voltage and no less than 75 % of the minimum power output voltage for a period not exceeding 1 ms

5 Marking

The power supply shall be marked in accordance with 4.15.1, EN 50131-1, and either EN 60950 or EN 60065 .

6 Documentation

The power supply shall be accompanied by documentation in accordance with EN 50131-1

Additionally, the documentation shall contain the following information:

- a) installation, commissioning, maintenance and operating instructions
- b) brief description of operation including characteristics of monitoring functions provided
- c) Type of PS (A, B or C)
- d) for Type A and B, voltage rating and frequency requirements of the EPS
- e) rated output of the power supply and maximum rated output of each independent power output
- f) the power requirement for any integrated component e.g. CIE, or the PS control circuitry
- g) output voltage range under normal operating conditions
- h) for PS with dc outputs, the maximum output peak to peak ripple voltage
- i) type of SD, its maximum capacity and maximum time to recharge
- j) the SD voltage below which the APS Fault: Low Voltage SD signal or message will be generated
- k) the voltage at any independent power output below which the Power Output Fault signal or message will be generated
- l) the SD voltage below which the Deep Discharge Protection function will operate
- m) over voltage protection trigger voltage
- n) connection details, including sufficient detail to enable effective interface and operation as part of the I&HAS
- o) electrical and logical characteristics of monitoring signals and messages e.g. volt-free contact, message protocols supported
- p) operating temperature and humidity range
- q) weights and dimensions
- r) fixing details
- s) details of type and value for any user serviceable components e.g. fuses
- t) details (e.g. frequency and procedure) of any required calibration checks and adjustments

7 Tests

The following tests shall be applied to PS Types A, B and C according to Table 7 below for the appropriate Grade as defined in Table 1. These tests are intended to be primarily concerned with verifying the correct operation of the power supply to the requirements of this standard and the specification provided by the manufacturer. All the test parameters specified shall carry a general tolerance of $\pm 10\%$ unless otherwise stated."

Table 7 — Tests for PS according to Type

Test	Title	Type A	Type B	Type C
1	Reduced Functional Test	✓	✓	✓
2	PS Rating	✓	✓	✓
3	Output Voltage Stability – Gradual Load variation	✓	✓	✓
4	Output Voltage Stability – Switched Load variation	✓	✓	✓
5	Signalling : Loss of EPS	✓	✓	
6	Signalling: Storage Device Low Voltage	✓	✓	✓
7	Signalling: Storage Device Failure	✓		
8	Signalling: Low Output Voltage	✓	✓	
9	Signalling: Power Unit Failure	✓	✓	
10	Signalling: Power Unit Failure – SD Charging	✓		
11	Remote Test Request	✓		
12	SD Recharging	✓		
13	Over-voltage Protection	✓	✓	
14	Short Circuit Protection	✓	✓	✓
15	Overload Protection	✓	✓	✓
16	Deep Discharge Protection	✓	✓	✓
17	Automatic Changeover to APS	✓	✓	
18	Tamper Protection	✓	✓	✓
19	Tamper Detection – Opening by Normal Means	✓	✓	✓
20	Tamper Detection – Removal from Mounting	✓	✓	✓
21	Tamper Detection – Penetration of Housing	✓	✓	✓
22	Environmental and EMC	✓	✓	✓
23	Documentation	✓	✓	✓
✓ = Test applicable for PS Type				

7.1 General test conditions

7.1.1 Standard laboratory conditions for testing

The general atmospheric conditions in the measurement and tests laboratory shall be those specified in EN 60068-1, 5.3.1, unless stated otherwise.

Temperature:	15 °C to 35 °C
Relative humidity:	25 % RH to 75 % RH
Air pressure:	86 kPa to 106 kPa

7.1.2 General detection testing environment and procedures

The PS manufacturer's documented instructions regarding mounting and operation shall be applied to all tests.

7.1.3 Signal or message processing time

Where the PS is integrated with another I&HAS component (e.g. CIE) or another component is the only means to indicate the generation of a signal or message, allowance shall be made for the processing time of that component.

7.1.4 Load electrical characteristics

The electrical characteristics of the load used in these tests shall have no reactive component.

7.1.5 SD Discharged Condition

A SD shall be considered to have reached its discharge condition if it has been subject to discharge from a fully charged state using a fixed current load over a period defined according to the SD manufacturer.

7.2 Reduced Functional Test

7.2.1 Principle

The principle of the reduced functional test consists of operating the PS under full load conditions to verify that the PS is operational before undergoing other tests (e.g. impact test, environmental test) and that it continues to function after these tests.

For Type A PS the test is carried out with a fully discharged SD and maximum EPS voltage.

For a Type B PS the test is carried out with a SD at any state of charge and maximum EPS voltage.

For a Type C PS the test is carried out with a SD of sufficient charge for its voltage at any independent power output to remain above the Storage Device - Low Voltage value.

7.2.2 Test conditions

Connect a SD of the maximum capacity specified for the PS. For PS Type A this SD shall be discharged to the minimum level as recommended by the SD manufacturer.

Connect a load to the PS that will demand the full rated output of the PS proportionately spread across all the independent power outputs according to the individual maximum rating of each independent power output.

7.2.3 Mounting

Mount the PS according to the PS manufacturer's instructions.

7.2.4 Procedure

7.2.4.1 Stimuli

For PS Type A and B apply an EPS voltage of 230 V AC +10 % to the PS at a frequency specified by the PS manufacturer.

Operate the PS.

Open the PS housing by normal means.

7.2.4.2 Measurement

Measure the voltage and ripple voltage at each independent power output.

Monitor the EPS, APS, Power Output Fault and Tamper signal or message outputs.

7.2.5 Pass/Fail criteria

Throughout the test, the voltage and ripple voltage at any independent power output shall remain within the limits specified by the manufacturer.

There shall be no EPS, APS or Power Output Fault signals or messages generated during the tests.

A Tamper signal or message shall be generated when the PS housing is opened by normal means.

7.3 PS Rating

7.3.1 Principle

The principle of this test is to verify the continuous rated output of the PS under full load conditions and for PS Type A and B, under maximum and minimum values of EPS voltage. This test is also to verify the specified power requirements of any integrated component or the PS control circuitry.

7.3.2 Test conditions

Connect a SD of the maximum capacity specified for the PS. For PS Type A this SD shall be discharged to the minimum level as recommended by the SD manufacturer.

Connect a load to the PS that will demand the full rated output of the PS proportionately spread across all the independent power outputs according to the individual maximum rating of each independent power output.

7.3.3 Mounting

Mount the PS according to the PS manufacturer's instructions.

7.3.4 Procedure

7.3.4.1 Stimuli

For PS Type A and B:

Apply an EPS voltage of 230 V AC - 15 % to the PS at a frequency specified by the PS manufacturer and operate the PS for 30 m.

Apply an EPS voltage of 230 V AC + 10 % to the PS and operate the PS for 24 h.

For PS Type C, operate the PS for 24 h.

At the end of the test period, disconnect the load and for PS Type A and B, disconnect the EPS.

7.3.4.2 Measurement

Measure the voltage and ripple voltage during the test at each independent power output.

Measure the quiescent current drawn from the SD by the PS control circuit and any other components within the PS housing e.g. CIE.

7.3.5 Pass/Fail criteria

Throughout the test, the voltage and ripple voltage at any independent power output shall remain within the limits specified by the manufacturer.

The quiescent current consumption of the PS control circuit or any integrated components shall be no more than that specified by the manufacturer.

7.4 Output Voltage Stability - Gradual Load Variation

7.4.1 Principle

The principle of this test consists of applying a continually varying load to one independent power output of the PS and verifying that there is no influence on any other independent power output.

7.4.2 Test conditions

Connect a variable load to one of the independent power outputs, capable of continuous adjustment to demand from 10 % to 100 % of the rating of that independent power output.

NOTE Where it is not possible to start this test from 10 % due to the fixed load of an integrated component I&HAS, then the variable load should be adjusted over the maximum available range

Connect a fixed load proportionately spread across all the other independent power outputs, according to their individual maximum rating. This fixed load will demand the full rated output of the PS when the tested output is at 100 % loading.

7.4.3 Mounting

Mount the PS according to the PS manufacturer's instructions.

7.4.4 Procedure

7.4.4.1 Stimuli

For PS Type A and B, apply an EPS voltage of 230 V AC at the frequency specified by the PS manufacturer.

Operate the PS.

Continuously increase the demanded load from 10 % to 100 % over a period of 10 s.

Continuously decrease the demanded load from 100 % to 10 % over a period of 10 s.

7.4.4.2 Measurement

Measure the voltage and ripple voltage during the test at each independent power output.

7.4.4.3 Repeat

For PS having two or more independent power outputs, repeat this test with the variable load connected to one of the other independent power outputs.

7.4.5 Pass/Fail criteria

Throughout the test, the voltage and ripple voltage at each independent power output shall remain within the limits specified by the PS manufacturer.

7.5 Output Voltage Stability – Switched Load Variation

7.5.1 Principle

The principle of this test consists of applying a switched load to one independent power output of the PS and verifying that there is no influence on any other independent power output.

7.5.2 Test conditions

Connect a load to one of the independent power outputs, capable of switching between 50 % to 100 % demand of the rating of that independent power output within 5 ms.

NOTE Where it is not possible to start this test from 50 % due to the fixed load of an integrated component I&HAS, then the variable load should be adjusted over the maximum available range

Connect a fixed load proportionately spread across all the other independent power outputs, according to their individual maximum rating. This fixed load will demand the full rated output of the PS when the tested output is at 100 % loading.

7.5.3 Mounting

Mount the PS according to the PS manufacturer's instructions.

7.5.4 Procedure

7.5.4.1 Stimuli

For PS Type A and B, apply an EPS voltage of 230 V AC at the frequency specified by the PS manufacturer.

Operate the PS.

Switch the load demand from 50 % to 100 %.

Switch the load demand from 100 % to 50 %.

7.5.4.2 Measurement

Measure the voltage and ripple voltage during the test at each independent power output. Monitor the voltage at each independent power output for transients.

7.5.4.3 Repeat

For PS having two or more independent power outputs, repeat this test with the switched load connected to one of the other independent power outputs.

7.5.5 Pass/Fail criteria

Throughout the test, the voltage and ripple voltage at each independent power output shall remain within the limits specified by the manufacturer.

Any transient voltages detected at the independent power outputs shall meet the requirements of 4.15.7.

7.6 Signalling: Loss of EPS

7.6.1 Principle

The principle of this test consists of verifying that an EPS Fault signal or message is generated within the specified time periods when the EPS is removed and cancelled within the specified time periods when the EPS is re-connected.

7.6.2 Test conditions

Connect a load demanding at least 10 % of the rated output of the PS to one of the independent power outputs.

7.6.3 Mounting

Mount the PS according to the PS manufacturer's instructions.

7.6.4 Procedure

7.6.4.1 Stimuli

Apply an EPS voltage of 230 V AC at the frequency specified by the PS manufacturer and operate the PS.

Remove the EPS for at least 61 s.

Re-apply the EPS for at least 61 s.

7.6.4.2 Measurement

Monitor the EPS Fault signal or message output of the PS.

7.6.5 Pass/Fail criteria

An EPS Fault signal or message shall be generated within 61 s after removal of the EPS.

The EPS Fault signal or message shall be removed within 61 s after reconnection of the EPS.

7.7 Signalling: Storage Device – Low Voltage

7.7.1 Principle

The principle of this test consists of simulating a dropping SD voltage and verifying that an APS Fault signal or message is generated at the SD voltage specified by the PS manufacturer.

7.7.2 Test conditions

Connect a load demanding at least 10 % of the rated output of the PS to one of the independent power outputs.

Simulate the presence of the SD by connecting a variable voltage power supply, or as advised by the PS manufacturer.

7.7.3 Mounting

Mount the PS according to the PS manufacturer's instructions.

7.7.4 Procedure – Phase I

7.7.4.1 Stimuli

For PS Type A and B, apply an EPS voltage of 230 V AC at the frequency specified by the PS manufacturer.

Verify that the initial simulated SD voltage represents a fully charged SD.

Operate the PS.

For Type A PS, remove the EPS.

Slowly reduce the simulated SD voltage until an APS Fault signal or message is generated.

Slowly increase the simulated SD voltage until the APS Fault signal or message is removed.

7.7.4.2 Measurement

Measure the simulated SD voltage at which the APS Fault signal or message is generated and removed.

Measure the time between the simulated SD voltage reaching and being increased from the SD Failure - Low Voltage value as specified by the PS manufacturer and the generation and removal of the APS Fault signal or message.

7.7.5 Procedure – Phase II

For Type A PS only.

7.7.5.1 Stimuli

With the EPS removed, slowly reduce the simulated SD voltage until an APS Fault signal or message is generated.

Re-apply the EPS.

7.7.5.2 Measurement

Measure the simulated SD voltage at which the APS Fault signal or message is generated and removed.

Measure the time between the re-connection of the EPS and the removal of the APS Fault signal or message.

7.7.6 Pass/Fail criteria

An APS Fault signal or message shall be generated and removed according to Table 2 within the maximum time periods defined in Table 3, when the voltage of the SD falls below the low value as specified by the PS manufacturer.

For PS Type A, the APS Fault signal or message shall be removed within the maximum time periods defined in Table 3, when the EPS is reconnected.

7.8 Signalling: Storage Device – Failure

7.8.1 Principle

The principle of this test consists of simulating a failed SD and verifying that an APS Fault signal or message is generated and removed within 24 h of the creation and removal of the SD failure condition.

7.8.2 Test conditions

Connect a load demanding at least 10 % of the rated output of the PS to one of the independent power outputs.

In conjunction with the PS manufacturer, connect a means of simulating a failed SD.

7.8.3 Mounting

Mount the PS according to the PS manufacturer's instructions.

7.8.4 Procedure – Phase I

7.8.4.1 Stimuli

Apply an EPS voltage of 230 V AC at the frequency specified by the PS manufacturer and operate the PS.

Simulate a failed SD and wait until an APS Fault signal or message has been generated or a period of 24 h has passed.

Reset the failed SD simulator to a normal healthy SD and wait until an APS Fault signal or message has been removed or a period of 24 h has passed.

7.8.4.2 Measurement

Monitor the time at which the APS Fault signal or message is generated and removed.

7.8.5 Procedure – Phase II

If the PS has the capability of operating with two or more storage devices in parallel, then the procedure of 7.8.4 shall be repeated for each SD.

7.8.6 Pass/Fail criteria

An APS Fault signal or message shall be generated and removed within 24 h of the creation and reset of a failed SD condition.

7.9 Signalling: Low Output Voltage

7.9.1 Principle

The principle of this test consists of creating an artificial low voltage on any one of the independent power outputs and verifying that a Power Output Fault signal or message is generated within 10 s.

7.9.2 Test conditions

Connect a load demanding at least 10 % of the rated output of the PS to one of the independent power outputs.

7.9.3 Mounting

Mount the PS according to the PS manufacturer's instructions.

7.9.4 Procedure

7.9.4.1 Stimuli

For PS Type A and B, apply an EPS voltage of 230 V AC at the frequency specified by the PS manufacturer.

Operate the PS.

In conjunction with the PS manufacturer, artificially create a voltage on one of the independent power outputs lower than the minimum power output voltage.

If the means to artificially create the low output voltage can be reversed, wait for at least 10 s after the power output fault signal or message has been generated, then restore the independent power output voltage to its normal value.

7.9.4.2 Measurement

Monitor the time at which the Power Output Fault signal or message is generated and removed.

7.9.5 Pass/Fail criteria

A Power Output Fault signal or message shall be generated and removed within 10 s of the creation and removal of the low output voltage condition.

7.10 Signalling: Power Unit Failure

7.10.1 Principle

The principle of this test consists of creating an artificial failure in the PU and verifying that a Power Output Fault signal or message is generated within 10 s.

7.10.2 Test conditions

Connect a load demanding at least 10 % of the rated output of the PS to one of the independent power outputs.

7.10.3 Mounting

Mount the PS according to the PS manufacturer's instructions.

7.10.4 Procedure

7.10.4.1 Stimuli

For PS Type A and B, apply an EPS voltage of 230 V AC at the frequency specified by the PS manufacturer.

Operate the PS.

In conjunction with the PS manufacturer, artificially create a failure in the PU.

7.10.4.2 Measurement

Monitor the time at which the Power Output Fault signal or message is generated.

7.10.5 Pass/Fail criteria

A Power Output Fault signal or message shall be generated within 10 s of the creation of the PU failure condition.

7.11 Signalling: Power Unit Failure – SD Charging

7.11.1 Principle

The principle of this test consists of simulating a failure in the PU SD charging circuit and verifying that a Power Output Fault signal or message is generated.

7.11.2 Test conditions

Connect a load demanding at least 10 % of the rated output of the PS to one of the independent power outputs.

Connect an SD of the maximum capacity specified for the PS. The SD shall be discharged to the minimum level as recommended by the SD manufacturer.

7.11.3 Mounting

Mount the PS according to the PS manufacturer's instructions.

7.11.4 Procedure

7.11.4.1 Stimuli

Apply an EPS voltage of 230 V AC at the frequency specified by the PS manufacturer and operate the PS.

In conjunction with the PS manufacturer, disable the SD charging circuit.

If the means to disable the SD charging circuit can be reversed, wait for 20 s and restore the SD charging circuit to its normal operation.

7.11.4.2 Measurement

Monitor the time at which the Power Output Fault signal or message is generated and removed.

7.11.5 Pass/Fail criteria

A Power Output Fault signal or message shall be generated and removed within 10 s of the SD charging circuit being disabled and restored to normal operation.

7.12 Remote Test Request

7.12.1 Principle

The principle of this test consists of triggering the internal tests of SD Failure in accordance with the PS manufacturer's instructions and verifying that the resulting test sequence does not prevent the PS from operating normally.

7.12.2 Test conditions

Connect a load demanding at least 10 % of the rated output of the PS to one of the independent power outputs.

In conjunction with the PS manufacturer, connect a means of simulating a failed SD.

7.12.3 Mounting

Mount the PS according to the PS manufacturer's instructions.

7.12.4 Procedure – Phase I

7.12.4.1 Stimuli

Apply an EPS voltage of 230 V AC at the frequency specified by the PS manufacturer and operate the PS.

Simulate a failed SD. Trigger the internal test of SD Failure by applying a Remote Test request signal or message according to the PS manufacturer's instructions.

Reset the failed SD simulator to a normal healthy SD. Re-trigger the internal test of SD Failure by applying a Remote Test request signal or message according to the PS manufacturer's instructions.

7.12.4.2 Measurement

Measure the voltage at each independent power output.

Measure the time at which the APS Fault signal or message is generated and removed.

Monitor the Tamper output.

7.12.5 Procedure – Phase II

If the PS has the capability of operating with two or more storage devices in parallel, then the procedure of 7.12.4 shall be repeated for one of the other SDs.

7.12.6 Pass/Fail criteria

Throughout the test, the voltage at each independent power output shall remain within the limits specified by the manufacturer.

An APS Fault signal or message shall be generated within 10 s of application of the Remote Test request signal.

The APS Fault signal shall be removed within 60 s of application of the Remote Test trigger signal unless the SD has failed the internal test.

No Tamper signal or message shall be generated during the triggering, application or signalling of results of the internal tests of SD Failure.

7.13 SD Recharging

7.13.1 Principle

The principle of this test consists of measuring the current supplied by the PU into a discharged SD over the grade dependant recharge period and verifying that during this period sufficient charge has been supplied to recharge the SD to 80 % of its rated capacity. This test is conducted with the PS under full rated load.

For a Grade 4 PS, the SD trickle charging voltage for a fully charged SD is verified to remain within the SD manufacturer's specified limits when the PS is cycled through its range of operating temperatures.

7.13.2 Test conditions

Connect a load to the PS that will demand the full rated output of the PS proportionately spread across all the independent power outputs according to the individual maximum rating of each independent power output.

Connect a SD of the maximum capacity specified for the PS. This SD shall be discharged to the minimum level as recommended by the SD manufacturer or the level at which the Deep Discharge Protection function of the PS has disconnected the SD during the APS operating period.

7.13.3 Mounting

Mount the PS according to the PS manufacturer's instructions.

A Grade 4 PS shall be mounted in a suitable test enclosure where the temperature can be varied between the minimum and maximum temperatures for the Environmental Class for which the PS is specified.

7.13.4 Procedure

7.13.4.1 Stimuli

Apply an EPS voltage of 230 V AC at the frequency specified by the PS manufacturer and operate the PS.

For a Grade 4 PS extend the maximum SD recharge period by 100 % to achieve full charge of the SD. Continue to operate the PS such that the SD is trickle charging. Cycle the temperature of the test enclosure twice between the maximum and minimum operating temperatures for the rated Environmental Class of the PS over a period of 24 h. Each cycle shall commence and end with the maximum temperature.

7.13.4.2 Measurement

Before connection of the EPS, measure the open circuit terminal voltage of the SD.

Measure the current supplied to the SD over the grade dependent maximum SD recharge period as defined in EN 50131-1.

For a Grade 4 PS, measure the ambient temperature of the SD and the charging current and voltage applied to the SD during the temperature cycled trickle charging period.

7.13.5 Pass/Fail criteria

The open circuit terminal voltage of the SD shall be above any minimum SD voltage specified by the manufacturer at which an SD shall be charged. Recharging of the SD shall automatically commence when the EPS is connected.

Sufficient current shall have been supplied to the SD to restore 80 % of the rated capacity of the SD during the maximum recharge period.

For a Grade 4 PS, the trickle charge current and voltage shall remain within the limits defined by the SD manufacturer over the test temperature range.

7.14 Over Voltage Protection

7.14.1 Principle

The principle of this test consists of simulating, or otherwise creating, a component failure of the PS to generate a high output voltage and verifying that this high voltage is limited to 125 % of the maximum power output voltage.

7.14.2 Test conditions

Connect a load demanding at least 10 % of the rated output of the PS to one of the independent power outputs.

7.14.3 Mounting

Mount the PS according to the PS manufacturer's instructions.

7.14.4 Procedure

7.14.4.1 Stimuli

For PS Type A and B, apply an EPS voltage of 230 V AC at the frequency specified by the PS manufacturer.

Operate the PS.

In conjunction with the PS manufacturer, simulate or otherwise create, a component failure in the PS to generate a high voltage greater than 125 % of the maximum power output voltage on one or more independent power outputs.

7.14.4.2 Measurement

Measure the voltage on all independent power outputs.

7.14.5 Pass/Fail criteria

The voltage on any independent power output shall not exceed 125 % of the maximum power output voltage of the PS.

7.15 Short Circuit protection

7.15.1 Principle

The principle of this test consists of applying a short circuit load to one or more independent power outputs of the PS and verifying that there is no influence on any other independent power output.

On removal of the short-circuit and reset of any protection device, the voltage and output current capability of all independent power outputs are verified that they operate within the PS manufacturer's specified limits.

7.15.2 Test conditions

Connect a load to one of the independent power outputs, capable of switching a demand between at least 10 % of the rating of that independent power output and a short circuit within 10 ms.

7.15.3 Mounting

Mount the PS according to the PS manufacturer's instructions.

7.15.4 Procedure - Phase 1

7.15.4.1 Stimuli

For PS Type A and B, apply an EPS voltage of 230 V AC at the frequency specified by the PS manufacturer.

Operate the PS.

Switch the load demand from at least 10 % to a short circuit.

7.15.4.2 Measurement

Measure the voltage and ripple voltage during the test at each unloaded independent power output.

Monitor the voltage at each unloaded independent power output for transients.

7.15.5 Procedure - Phase 2

7.15.5.1 Stimuli

Remove the short circuit and reset any protection device, if applicable.

Connect a load to the test output that will demand 100 % of the rating of that output.

Operate the PS.

7.15.5.2 Measurement

Measure the voltage and ripple voltage during the test at each independent power output.

7.15.6 Repeat

For PS having two or more independent power outputs, repeat this test with the switched load connected to each of the other independent power outputs in turn.

7.15.7 Pass/Fail criteria

Throughout the test, the voltage and ripple voltage at each independent power output except the short-circuit output shall remain within the limits specified by the manufacturer.

Any transient voltages detected at the unloaded independent power output shall meet the requirements of 4.15.7.

7.16 Overload Protection

7.16.1 Principle

The principle of this test consists of applying an overload to one or more independent power outputs of the PS and verifying that there is no influence on any other independent power output.

On removal of the overload condition and reset of any protection device, the voltage and output current capability of all independent power outputs are verified that they operate within the PS manufacturer's specified limits.

7.16.2 Test conditions

Connect a variable load to one of the independent PS outputs, capable of continuous adjustment from 10 % to 150 % demand of the rating of that independent power output.

NOTE Where it is not possible to start this test from 10 % due to the fixed load of an integrated component I&HAS, then the variable load should be adjusted over the maximum available range

7.16.3 Mounting

Mount the PS according to the PS manufacturer's instructions.

7.16.4 Procedure Phase 1

7.16.4.1 Stimuli

For PS Type A and B, apply an EPS voltage of 230 V AC at the frequency specified by the PS manufacturer.

Operate the PS.

Vary the load demand from 10 % to 150 % over a period of 10 s.

7.16.4.2 Measurement

Measure the voltage and ripple voltage during the test at each unloaded independent power output.

Monitor the voltage at each unloaded independent power output for transients.

7.16.5 Procedure - Phase 2

7.16.5.1 Stimuli

Remove the overload condition and reset any protection device, if applicable.

Connect a load to the test output that will demand 100 % of the rating of that output.

Operate the PS.

7.16.5.2 Measurement

Measure the voltage and ripple voltage during the test at each independent power output.

7.16.6 Repeat

For PS having two or more independent power outputs, repeat this test with the variable load connected to each of the other independent power outputs in turn.

7.16.7 Pass/Fail criteria

Throughout the test, the voltage and ripple voltage at each unloaded independent power output except the overloaded output shall remain within the limits specified by the manufacturer.

Any transient voltages detected at the unloaded independent power output shall meet the requirements of 4.15.7

7.17 Deep Discharge Protection

7.17.1 Principle

The principle of this test consists of simulating a dropping SD voltage during the APS operating period and verifying that the SD is disconnected at the Deep Discharge Protection voltage specified by the PS manufacturer.

7.17.2 Test conditions

Connect a load demand of at least 10 % of the rated output of the PS to one of the independent power outputs.

Simulate the presence of the SD by connecting a variable voltage power supply, or as advised by the PS manufacturer.

7.17.3 Mounting

Mount the PS according to the PS manufacturer's instructions.

7.17.4 Procedure

7.17.4.1 Stimuli

For PS Type A and B, apply an EPS voltage of 230 V AC at the frequency specified by the PS manufacturer.

Verify that the initial simulated SD voltage represents a fully charged SD.

Operate the PS to verify correct power output voltage.

For Type A and B PS, remove the EPS.

Slowly reduce the simulated SD voltage.

7.17.4.2 Measurement

Measure the simulated SD voltage at which the SD is disconnected from the load.

Measure the voltage at each independent power output.

7.17.5 Pass/Fail criteria

The SD shall be disconnected from the load when the voltage of the SD falls below the Deep Discharge Protection value as specified by the PS manufacturer.

The voltage at each independent power output shall have reduced below the minimum power output voltage before the SD is disconnected.

7.18 Automatic Changeover to APS

7.18.1 Principle

The principle of this test consists of verifying that no excessive transient voltages are generated during the changeover period between EPS and APS operation.

7.18.2 Test conditions

Connect a load to the PS that will demand the full rated output of the PS proportionately spread across all the independent power outputs according to the individual maximum rating of each independent power output.

Connect an SD of maximum rated capacity that is charged to greater than 80 % of its rated capacity.

7.18.3 Mounting

Mount the PS according to the PS manufacturer's instructions.

7.18.4 Procedure

7.18.4.1 Stimuli

Apply an EPS voltage of 230 V AC at the frequency specified by the PS manufacturer.

Operate the PS.

Disconnect the EPS.

7.18.4.2 Measurement

Measure the voltage during the test at each independent power output.

7.18.5 Pass/Fail criteria

The voltage throughout the test at each independent power output shall remain within the limits specified by the PS manufacturer.

Any transient voltages detected at the independent power outputs shall meet the requirements of 4.15.7

7.19 Tamper Protection

7.19.1 Principle

The principle of this test is to use Impact testing to verify that the PS housing meets the tamper protection requirements of 4.11.1.

7.19.2 Procedure

7.19.2.1 Stimuli

Subject the PS housing to impact tests in accordance with EN 50130-5 at the severity level specified in 4.11.1.

7.19.2.2 Measurement

Assess the PS as described in the reduced functional test in 7.1.

7.19.3 Pass/Fail criteria

The PS shall meet the requirements of the reduced functional test before, during and after the environmental tests.

The generation of signals or messages is permitted as a result of this test.

There shall be no signs of mechanical damage that will reduce the integrity of the PS housing unless a tamper signal or message has been generated.

7.20 Resistance to and detection of unauthorised access to components and means of adjustment

7.20.1 Principle

The principle of this test is to verify that it is not possible to insert a tool into the PS in its normal mounting position and defeat the operation of the tamper detection circuitry or otherwise adversely affect the operation without generating a tamper signal or message or causing visible damage.

7.20.2 Test conditions

Connect a load demanding at least 10 % of the rated output of the PS to one of the independent power outputs.

7.20.3 Mounting

Mount the PS according to the manufacturer's instructions with the housing secured closed.

7.20.4 Procedure

7.20.5 Stimuli

For PS Type A and B, apply an EPS voltage of 230 V AC at the frequency specified by the PS manufacturer.

Operate the PS.

Using the tools specified in EN 50131-1 and by attempting to distort the housing attempt to gain access to all components, means of adjustment and mounting screws, which, when interfered with, could adversely affect the operation of the PS.

7.20.5.1 Measurement

Measure the voltage of the PS at each independent power output.

Monitor the EPS, APS, Power Output Fault and Tamper signal or message outputs of the PS.

7.20.6 Pass/Fail criteria

Normal access shall require the use of an appropriate tool. For the grades specified in Table 4, it shall not be possible to gain access to any components, means of adjustment and mounting screws, which, when interfered with, could adversely affect the operation of the PS, without generating a tamper signal or message or causing visible damage.

The voltage throughout the test at each independent power output shall remain within the limits specified by the manufacturer.

7.21 Tamper Detection – Removal from Mounting

7.21.1 Principle

The principle of this test consists of removing the PS from its mounting surface and monitoring the PS to determine whether a Tamper signal or message is generated within the required time period and maximum permitted distance

7.21.2 Test conditions

Connect a load demanding at least 10 % of the rated output of the PS to one of the independent power outputs.

7.21.3 Mounting

Position the PS sample on a horizontal flat surface, taking into account any requirements specified by the manufacturer to operate the removal from mounting detection device

7.21.4 Procedure

7.21.4.1 Stimuli

For PS Type A and B, apply an EPS voltage of 230 V AC at the frequency specified by the PS manufacturer.

Operate the PS.

Lift the PS from the flat surface in a perpendicular direction to the mounting surface by the distance specified in 4.11.2.2, whilst monitoring the Tamper signal or message output.

Attempt to slide a test blade as defined in 4.11.2.2 to defeat the removal from mounting detection before and during the above test.

7.21.4.2 Measurement

Monitor the Tamper signal or message output.

Record whether it was possible to prevent the generation of a Tamper signal or message using the test blade.

7.21.5 Pass/Fail criteria

The Tamper signal or message shall have been generated within 11 s of the PS reaching the distance specified in 4.11.2.2.

It shall not have been possible to prevent the generation of a Tamper signal or message using the test blade.

7.22 Tamper Detection – Penetration of the housing

7.22.1 Principle

The principle of this test consists of drilling a hole in an accessible face of the PS housing and verifying that a Tamper signal or message is generated .

7.22.2 Test conditions

Connect a load demanding at least 10 % of the rated output of the PS to one of the independent power outputs.

7.22.3 Mounting

Mount the PS according to the PS manufacturer's instructions.

7.22.4 Procedure

7.22.4.1 Stimuli

For PS Type A and B, apply an EPS voltage of 230 V AC at the frequency specified by the PS manufacturer.

Operate the PS.

Drill a hole of 4 mm diameter in any accessible face of the PS using a metal drill bit.

7.22.4.2 Measurement

Monitor the Tamper signal or message output.

7.22.5 Pass/Fail criteria

A Tamper signal or message shall be generated when a hole of 4 mm is made in any accessible face of the PS housing.

7.23 Environmental and EMC

7.23.1 Principle

The principle of this test is to verify using the Reduced Functional Test of 7.1 that the PS will operate correctly during or after given environmental conditioning without significant mechanical damage or degradation of performance.

7.23.2 Procedure

7.23.2.1 Stimuli

Subject the PS to the tests given in Table 6, in accordance with EN 50130-5, EN 50130-4 and EN 61000-6-3 applying the reduced functional test of 7.1, before, during and after each conditioning, inclusive of any recovery period specified in EN 50130-5. The tests shall be applied to the sample number of the product under test in accordance with Table 6.

NOTE It is not necessary to open the PS enclosure by normal means during operational tests.

For Type A PS the SD is permitted to charge during the operational tests and remain at its final state of charge for the reduced functional test applied after the environmental conditioning.

7.23.2.2 Measurement

Assess the PS as described in the reduced functional test in 7.1.

7.23.3 Pass/Fail criteria

The PS shall meet the requirements of the reduced functional test before, during and after the environmental tests in accordance with Table 6.

There shall be no signs of mechanical damage that will reduce the integrity of the PS housing.

The shock and impact tests may generate transient signals or messages, but these shall not be present for longer than 200 ms.

For EMC tests, the PS shall operate within the limits defined in EN 50130-4 and EN 61000-6-3.

7.24 Marking and Documentation

7.24.1 Principle

The principle of this test consists of verifying that the marking of the PS and the documentation supplied with the PS meets the requirements of Clauses 5 and 6.

7.24.2 Procedure

Examine the marking of the PS.

Examine the documentation supplied by the PS manufacturer.

7.24.3 Pass/Fail criteria

The marking on the PS shall meet the requirements of Clause 5 of this standard.

The documentation shall meet the requirements of Clause 6 of this standard.

Annex A (informative)

Determination of Storage device failure

One means to determine if the storage device is healthy is to apply a load to the SD for a defined minimum period of time and verify that its voltage remains above the minimum power output voltage level.

The following example methods are deemed to meet this requirement.

- a) With the SD disconnected from the PU (which is therefore operating from the EPS only), a load is applied to the SD at least equal to the maximum rated load and for a minimum time period appropriate for the type of SD in use, see Table A.1 below. During application of this load the voltage at the output of the SD must not fall below the minimum permissible operating voltage of the system and there must be no impact upon the normal operation of the PU. Should the SD be detected as faulty, or the EPS fail, the output of the power supply must immediately be returned to normal operation.
- b) The voltage of a programmable PU may be reduced in a controlled manner to a level such that the SD is switched into circuit as the power source for a minimum time period appropriate for the type of SD in use, see Table A.1 below. During the test period, a load is applied to the independent power outputs of the PS at least equal to its maximum rated load. The voltage at each independent power output must not fall below the minimum power output voltage. Should the SD be detected as faulty, or the EPS fail, the output of the power supply must immediately be returned to normal operation.

Table A.1 — Minimum Load times for Common Storage Devices in Use in I&HAS

Type of Storage Device	Minimum Load time	Notes
Lead Acid Battery	10 s	
Other rechargeable Battery	1 s	e.g. NiCd, NiMH etc